

**LEGEND**

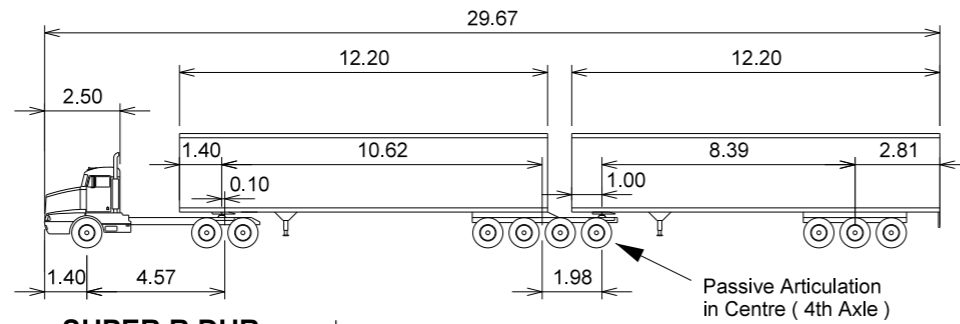
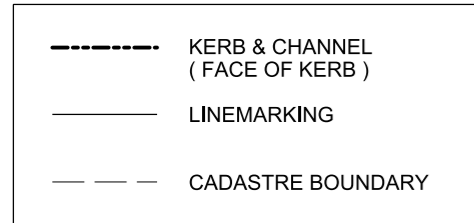

**SUPER B DUB :** meters  
 Tractor Width : 2.59 Lock to Lock Time : 6.00  
 Trailer Width : 2.59 Steering Angle : 23.53  
 Tractor Track : 2.59 Articulating Angle : 70.00  
 Trailer Track : 2.59

**SUPER B DOUBLE PROFILE**

NOT TO SCALE

TENANT LEASE AREA

TENANT LEASE AREA

SUPER-B-DOUBLE STANDARD DRIVEWAY REFER PLAN 112029

TENANT LEASE AREA

TENANT LEASE AREA

R-24.25

R-24.25

R-24.25

R-24.25

4.25  
14.00  
22.50

40.00  
4.25  
14.00  
22.50

**DESIGN INFORMATION**

REV.	AMENDMENT	INIT.	DATE
-	-	-	-
-	-	-	-
-	-	-	-
-	-	-	-
-	-	-	-

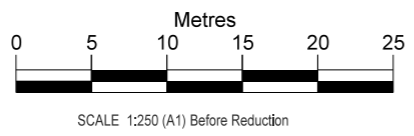

ENGINEERING:	Date:	HORIZ DATUM	FIG	VERT DATUM	PORT
PLANNING:	Date:	Based on		Based on	
ENVIRONMENT:	Date:	PREPARED by	Adam Jamison	Date:	13/05/2011
DREDGING:	Date:	CHECKED by		Date:	
		APPROVED by		Date:	

**STANDARDS FOR 30m SUPER B DOUBLE DRIVEWAY MINIMUM 40m SEPARATION DETAILS**

RPEQ No: ( If Required ) © PORT OF BRISBANE PTY LTD, 2011

PORT OF BRISBANE PTY LTD.  
 PORT OFFICE  
 PORT CENTRAL AVENUE  
 PORT OF BRISBANE  
 QUEENSLAND 4178  
 Phone 07 32584888  
 Fax 07 32584704  
 Email portbris@portbris.com.au

Dwg. No. 125232 Rev. -